



# FireNET L@titude Network Module (S723) Information Guide



---

# CONTENTS

---

<b>Contents</b> .....	<b>2</b>
<b>Compliance</b> .....	<b>3</b>
Underwriters Laboratories (UL) .....	3
FCC .....	3
Installation .....	3
<b>Introduction</b> .....	<b>4</b>
Technical Support .....	4
Return Material Authorization (RMA) .....	4
Warranty Service .....	5
Advanced Replacements .....	5
<b>Overview</b> .....	<b>6</b>
<b>Installation</b> .....	<b>7</b>
Before You Begin .....	8
Placement .....	8
Network Connections .....	9
Testing .....	11
<b>Troubleshooting</b> .....	<b>13</b>
<b>Specifications</b> .....	<b>14</b>
Electrical .....	14
Operating Environment .....	14
<b>Index</b> .....	<b>15</b>

# COMPLIANCE

## Underwriters Laboratories (UL)

---

Fire Alarm Subassembly  
Hochiki America Corporation

## FCC

---

This equipment has been tested and found to comply with the limits for a Class A digital device, pursuant to Part 15 of the FCC Rules. These limits are designed to provide reasonable protection against harmful interference when the equipment is operated in a commercial environment. This equipment generates, uses, and can radiate radio frequency energy and, if not installed and used in accordance with the Installation Manual, may cause harmful interference to radio communications. Operation of this equipment in a residential area is likely to cause harmful interference in which case the user will be required to correct the interference at his own expense. Any changes or modifications not expressly approved by Hochiki America Corporation could void the user's authority to operate this equipment under the rules and regulations of the FCC.

Operation is subject to the following two conditions:

- (1) This device may not cause harmful interference, and
- (2) This device must accept any interference received, including interference that may cause undesired operation.

## Installation

---

Install this product in accordance with NFPA 13, NFPA 72, NFPA 70, and NEC 70 and all local codes.

All field wiring should be installed using fire rated cables according to the NFPA 72. Riser conductors shall be installed in accordance with the survivability from attack by fire requirements in National Fire Alarm Code, NFPA 72, Section 12.3. Riser conductors shall employ either a 2 hour rated cable system, or meet requirements approved by the AHJ.

# INTRODUCTION

## Technical Support

---

For technical support, contact Hochiki America at 800.845.6692 or [technicalsupport@hochiki.com](mailto:technicalsupport@hochiki.com). Hochiki technical support is available Monday through Friday, 7:00AM to 5:00PM, PST.

Prior to contacting technical support, have the following information available:

- Product part number
- Purchase order or order number
- Product serial number
- Current function of the product
- Expected function of the product
- Installation of the product

## Return Material Authorization (RMA)

---

Contact Technical Support to obtain an RMA for any product to be returned. Returns will not be accepted without an accompanying RMA number. An RMA number is assigned when:

- Tech Support acknowledges a possible product failure.
- A product was damaged during shipping
- An incorrect product was shipped
- An order was placed using an incorrect part number \*
- An order was placed using an incorrect part quantity \*
- An order is no longer required \*

\* Restocking fees may apply.

All returned products are tested to confirm operating failures experienced in the field. If the product is found to be functional, contractors must absorb expenses for return shipping, as well as the cost and shipping of the advanced replacement product.

Prominently display the RMA number on all packages sent for return. Ship all return products to:

Attention: RMA # \_\_\_\_\_  
Hochiki America

7051 Village Park Drive, Suite 100  
Buena Park, CA 90621

## Warranty Service

---

Technical Support can replace or repair a defective product when the original purchase is within the warranty period defined in the sales contract. Check your contract for more information, or contact your sales representative about your specific warranty period.

### Advanced Replacements

Products that fail to operate in the field can be replaced quickly using the advanced replacement process. The advanced replacement process is available to all contractors who maintain an acceptable line of credit.

Initiate the advanced replacement process by requesting an RMA number from a Tech Support representative. Advanced replacements can be shipped to your location when the product is covered under warranty and when a replacement product is in stock.

- Advanced replacements can be expedited at the request of the contractor. Shipping costs associated with this process are the responsibility of the contractor.
- Products returned using the advanced replacement process must be received within 30 days of the RMA issue date.

## OVERVIEW

The L@titude Network Module (S723) provides supervised, enhanced high-speed communication for networking up to a maximum of 127 fire control panels. The network provided by this module can support combinations of FireNET L@titude Fire Alarm Control Panels and L@titude Vision Annunciators.

FireNET L@titude Fire Alarm Control Panels can receive events from other panels in the network. The Class X networking used in conjunction with the Network Module provides tolerance against open and short circuit trouble conditions.

The L@titude Network Module can be configured to operate in a "bridge mode", which enables the FireNET L@titude Fire Alarm Control Panel to operate on a network with FireNET and FireNET Plus panels. The FireNET and FireNET Plus network can support up to 64 fire control panels, and has other limitations, such as more limited text-field lengths, zones, C&E relationships, etc.





# INSTALLATION

This section explains the installation procedure for the L@titude Network Module (S723).

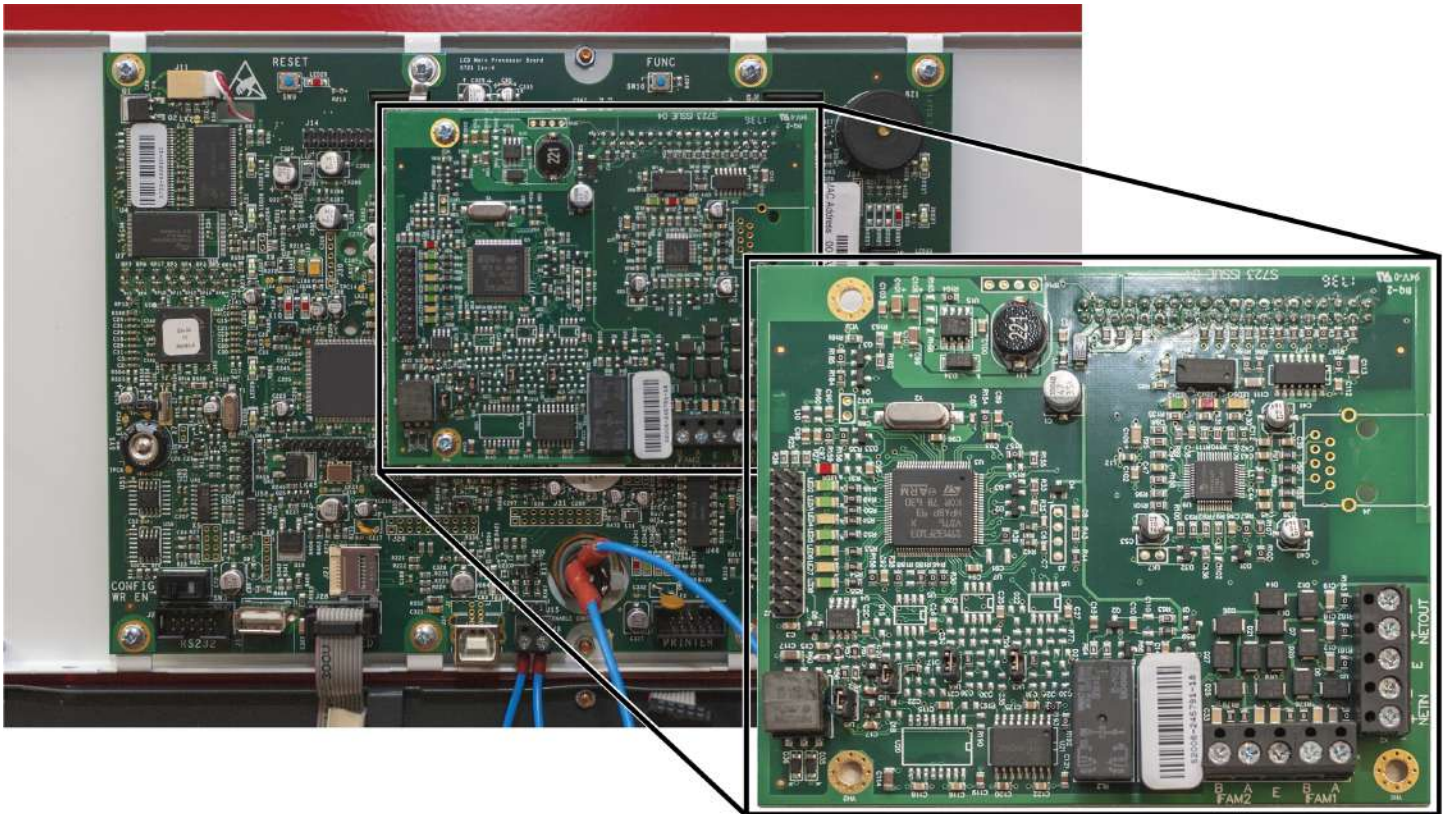

- Notify the monitoring center and location security that the FireNET L@titude Fire Alarm Control Panel will be temporarily out of service.
- Remove the module from its packaging and check its contents.
- Connect field wiring. Refer to [Network Connections](#) below for wiring information.
- Remove AC and battery power from the panel.
- Connect the 40 conductor connector of the Network Module to the 40 conductor connector of the LCD Main Processor Board.
- Secure the Network Module to the LCD Main Processor Board with supplied hardware.
- Restore AC and battery power.
- Wait for the panel start-up process to complete. Refer to the **FireNET L@titude Fire Alarm Control Panel Installation Manual (MAN-1431HA)** for more information.
- Test communication from the panel via the [LED Status Indicators](#).

Install this product in accordance with NFPA 72, the National Electrical Code, and all local codes.

---

**WARNING!** The module must be installed by personnel familiar with electronic components. Electronic components within the module are vulnerable to damage from electrostatic discharge. Ground straps must be worn by installers before handling to prevent electrostatic discharge damage.

---

## Before You Begin

---

Before you begin the installation, take a few minutes to review the installation information, gather the required items, and complete the tasks listed below to make the installation as quick and easy as possible:

Acquire the following item that is not included, but may be required for installation:

- **Ground Strap** - A ground strap is required for handling circuit boards. The ground strap is not provided in the packaging.

## Placement

---

The Network Module provides enhanced high-speed communication for networking up to 127 fire control panels, (addressed from 1-127). To install the network module of the FireNET L@titude Fire Alarm Control Panel:

1. Switch off AC power and disconnect the battery .
2. Connect the 40 conductor connector of the Network Module to the 40 conductor connector of the LCD Main Processor Board as shown.



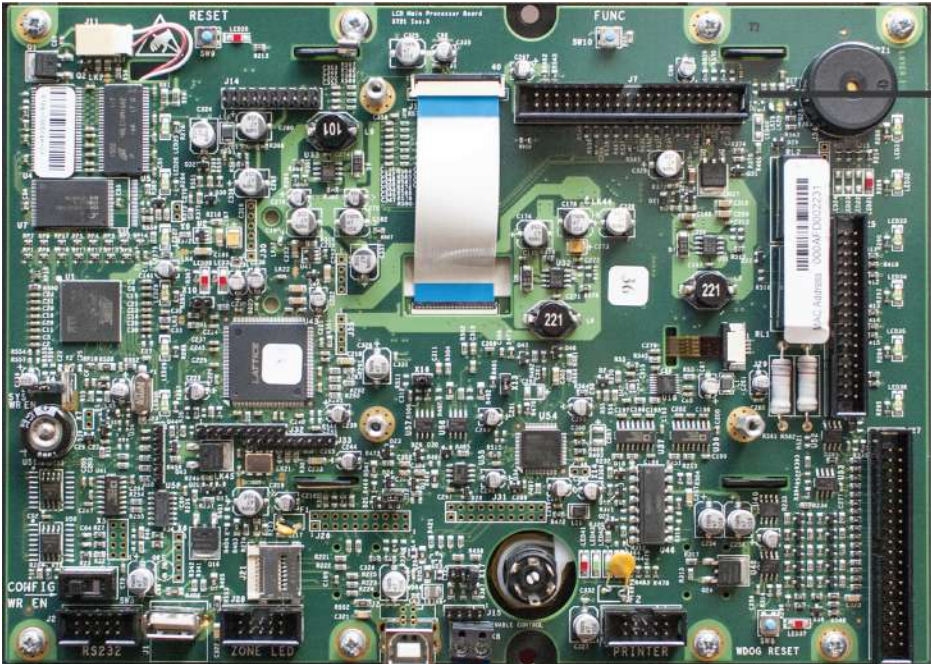

40 CONDUCTOR CONNECTOR FOR CONNECTING THE NETWORK MODULE

3. Secure the Network Module to the LCD Main Processor Board with supplied hardware .
4. Reconnect the battery and restore AC power.

## Network Connections

Provide network connections to NETWORK IN and NETWORK OUT terminals of the FireNET L@titude Fire Alarm Control Panel's Main Back Board after installing the Network Module. The following figure illustrates the typical network connections of a 3 panel, Class X network:

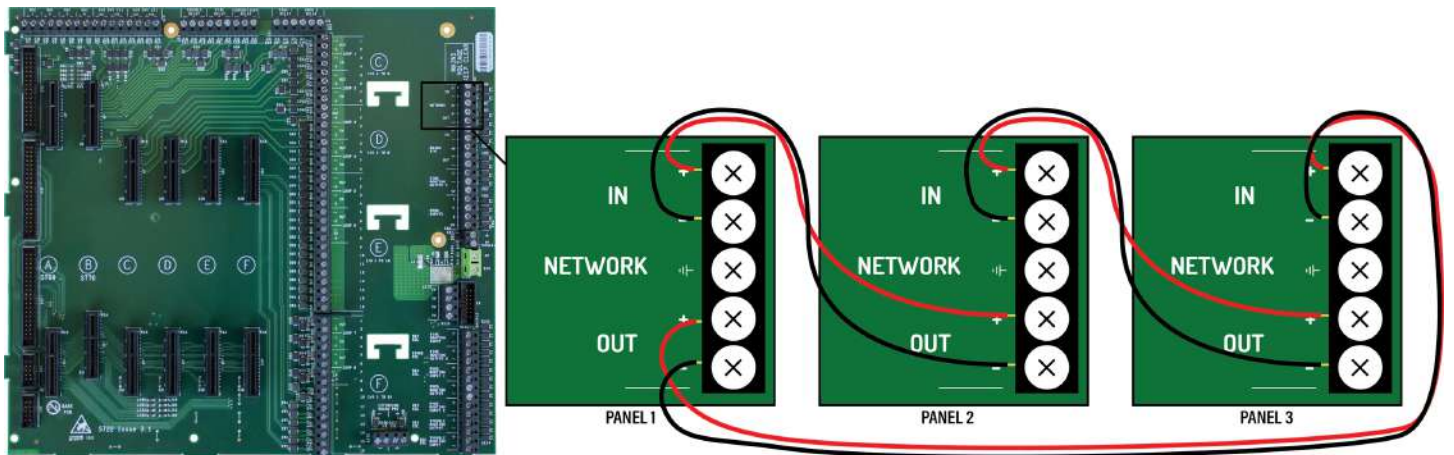

Because network connections are supervised, if a network module is installed and there are no other devices on the network, the IN and OUT network terminals must be connected together to prevent an OPEN CIRCUIT TROUBLE indication.

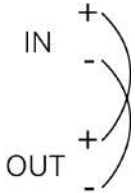

Bridge networking is supported for FireNET and FireNET Plus panels. Advanced features are not available when using bridge networking.

Field wiring must be connected in order for the Network Module to operate properly. A singular panel installation must be wired as shown.

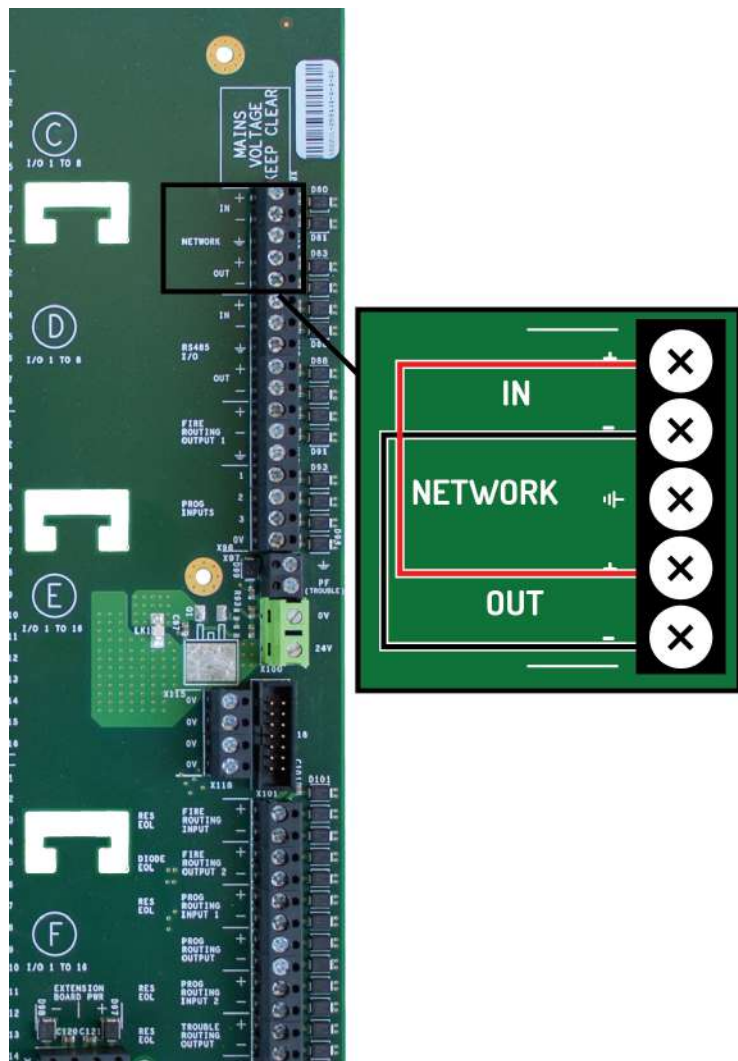

## Testing

LED indicators provide diagnostic information to identify communication.

LED Label	Name	Color	Description
LED 1	Heartbeat	Red	Identifies functional status.
LED 2	Tx Comms	Green	A blinking green light indicates that the module is transmitting data.
LED 3	Rx Comms	Green	A blinking green light indicates that the module is receiving data.
LED 4	Trouble	Yellow	A flashing yellow identifies an error condition.
LED 5	Unused	Green	Unused

LED Label	Name	Color	Description
LED 6	Unused	Green	Unused
LED 7	Unused	Yellow	Unused
LED 8	Comms for SPI Bus	Green	Communication present when flashing
LED9	Full Duplex	Yellow	Full duplex (on) half duplex (off)
LED 10	Ethernet Speed	Red	10MHz (off), 100MHz (on)
LED 12	Communication	Green	Communication present when flashing

# TROUBLESHOOTING

The following network-related troubles can occur on the FireNET L@titude Fire Alarm Control Panel. See the detailed descriptions below for explanations on each trouble message.

Trouble Message	Description
Network Communications Trouble	This event indicates there is no communication between this panel and its neighbor. This could be caused by a configuration error (such as using the wrong baud rate), a wiring error, or damage to the wires connecting the panel to its neighbor. If this trouble occurs on one link on the panel, then the panel is still in communication with other panels on the network. If this trouble occurs on both links on the panel, then the panel is no longer in communication with other panels on the network.
Unexpected Network Node	This event indicates a panel has been detected on the network that is not in the configuration. This is a configuration error, and should never occur once the network has been properly configured.
Network Card Missing	This event indicates that the panel is configured for networking, but there is no network card installed, or it is installed incorrectly. This trouble may also occur if the network card processor fails.
Connection Error	This event indicates that the panel has failed to get a meaningful result for the link impedance measurement. This may occur if stray leakage current enters the link wiring from elsewhere, or if there is a component failure or missing jumper on the network card. This event may also be shown when the network is disconnected or when the NET OUT + wire is disconnected.
Network Panel Missing	This event indicates that another panel is configured but has not been found on the network. This may occur if the missing panel is switched off or disconnected from the network. This fault will also occur if there is no communication between a panel and either of its neighbors on both links. In this case, the panel will show multiple instances of this trouble; one for each other panel on the network.
Network Node Double Addressed	This event indicates that more than one panel on the network has the same node number. This is a configuration error, and should never occur once the network has been properly configured.
Full Short Circuit Trouble	This event indicates that a short circuit has been detected by the link impedance measurement. This indicates a wiring error, or damage to the wires connecting the panel to its neighbor.
Full Open Circuit Trouble	This event indicates that an open circuit has been detected by the link impedance measurement. This indicates a wiring error, or damage to the wires connecting the panel to its neighbor. The following two troubles are optional, and are not included in the default firmware build.
Partial Short Circuit Trouble	This event indicates that the link impedance measurement has detected an impedance below the normally expected range.
Partial Open Circuit Trouble	This event indicates that the link impedance measurement has detected an impedance above the normally expected range.

# SPECIFICATIONS

This appendix provides specifications for the Network Module.

## Electrical

---

Protocol	RS-485
Supply Voltage Range	L@titude Network Vision Annunciator: 21 - 30V DC L@titude Fire Alarm Control Panel: 24V DC

## Operating Environment

---

Dry indoor use only.

Temperature Range	23°F (-5°C) - 120°F (49°C)
Relative Humidity	Up to 95%, non-condensing



# INDEX

---

## 2

24V 14

## C

Class A 3

Class X 6, 9

## H

Heartbeat 11

## L

LCD Main Processor Board 7

## N

Network 6-7, 13-14

## T

Terminals 9

Trouble 6, 10